

Déclaration UE de conformité CE – DoP

CE 090-046580 / CE 090-046582

1. Code d'identification unique du produit type:	
SCELLEMENT CHIMIQUE – RESINE POLYESTER – POLIFIX / POLIBLUE	
2. Usage(s) prévu(s) - 1 – Matériaux pleins	
Type générique et utilisation prévue	Scellement chimique pour l'ancrage de tiges filetées.
Matériau support	Béton non fissuré C20/25 to C50/60 selon EN 206-1:2000-12. Dimensions de tige M8 – M24. Béton Sec/Humide ou trous inondés.
Eléments à fixer	a) Acier au carbone classe 4.6, 5.8, 8.8 and 10.9 selon EN ISO 898-1 pour conditions d'usage en intérieur / sec. b) Acier inoxydable A4-70, A4-80 selon EN ISO 3506 pour conditions d'usage en intérieur / sec, exposition au milieu extérieur (y compris milieu industriel et marine) ou exposition permanente zn milieu humide si aucun agent agressif particulier n'est présent. c) Acier inoxydable haute résistance 1.5429 selon EN 10088 pour toutes conditions.
Longévité	50 années
Charges	Statique et quasi-statique
Plages de température	-40°C à +80°C (temperature max court terme +80°C / max. long terme +50°C)
Catégorie d'utilisation	Category 1: Béton sec ou humide.
Résistance au feu	Aucune performance évaluée dans l'ETA
2. Usage(s) prévu(s) - 3 – Matériaux creux	
Type générique et utilisation prévue	Scellement chimique pour l'ancrage de tiges filetées.
Matériau support	Maçonnerie creuse ou perforée. La classe de solidité du mortier de la maçonnerie doit être de 2.5 minimum selon EN 998-2:2010.
Eléments à fixer	Acier au carbone classe 5.8 selon EN ISO 898-1. Conditions sec en intérieur.
Longévité	50 années
Charges	Statique et quasi-statique
Plages de température	-40°C à +80°C (temperature max court terme +80°C / max. long terme +50°C)

Déclaration UE de conformité CE – DoP

CE 090-046580 / CE 090-046582

Résistance au feu	Aucune performance évaluée dans l'ETA
3. Fabricant	
BATIFIX SAS – France (42450) Rue de la roseliere 42450 – Sury Le Comtal France	
4. Système(s) d'évaluation et de vérification de la constance des performances:	
Système 1	
5. Document d'évaluation européen:	
Organisme d'évaluation technique (TAB) : TZUS - Technicky a Zkusebni Ustav Stavebni Praha s.p. Organisme(s) notifié(s) (NB) : TZUS (1020) Évaluation technique européenne: ETA-20/0080 du 17/01/2020 selon EAD 330499-00-0601 Évaluation technique européenne: ETA-20/0079 du 17/01/2020 selon EAD 330076-00-0604	

Déclaration UE de conformité CE – DoP

CE 090-046580 / CE 090-046582

6. Performance(s) déclarée(s):

Basic requirements on works. Intended use 1: Anchorage of threaded rods in concrete.			Performances						Technical Specification
			M8	M10	M12	M16	M20	M24	
Installation Parameters									
d _o	Nominal drill bit diameter	mm	10	12	14	18	22	26	EAD 330499-01-0601
T _{inst}	Installation torque	Nm	10	20	40	80	120	160	
h _{ef,min} = 8d									
h ₀	Depth of drilled hole	mm	64	80	96	128	160	192	EAD 330499-01-0601
s _{min}	Minimum spacing	mm	40	40	40	60	80	95	
c _{min}	Minimum edge distance	mm	40	40	40	60	80	95	
h _{min}	Minimum thickness of concrete member	mm	h _{ef} + 30 mm ≥ 100 mm				h _{ef} + 2d _o		
h _{ef,max} = 12d									
h ₀	Depth of drilled hole	mm	96	120	144	192	240	288	EAD 330499-01-0601
s _{min}	Minimum spacing	mm	40	40	40	60	80	95	
c _{min}	Minimum edge distance	mm	40	40	40	60	80	95	
h _{min}	Minimum thickness of concrete member	mm	h _{ef} + 30 mm ≥ 100 mm				h _{ef} + 2d _o		

Basic requirements on works. Intended use 1: Anchorage of threaded rods in concrete.			Performances						Technical Specification
			M8	M10	M12	M16	M20	M24	
Tension Load: Steel Failure									
N _{Rk,s}	Characteristic tension resistance for galvanised steel class 4.6	kN	15	23	34	63	98	141	EAD 330499-01-0601
γ _{Ms}	Partial safety factor for tension resistance for galvanised steel class 5.8	-	2.0						
N _{Rk,s}	Characteristic tension resistance for galvanised steel class 5.8	kN	18	29	42	79	123	177	
γ _{Ms}	Partial safety factor for tension resistance for galvanised steel class 5.8	-	1.5						
N _{Rk,s}	Characteristic tension resistance for galvanised steel class 8.8	kN	29	46	67	126	196	282	
γ _{Ms}	Partial safety factor for tension resistance for galvanised steel class 8.8	-	1.5						
N _{Rk,s}	Characteristic tension resistance for galvanised steel class 10.9	kN	37	58	84	157	245	353	
γ _{Ms}	Partial safety factor for tension resistance for galvanised steel class 10.9	-	1.4						
N _{Rk,s}	Characteristic tension resistance for stainless steel class A4-70	kN	26	41	59	110	172	247	
γ _{Ms}	Partial safety factor for tension resistance for galvanised steel class A4-70	-	1.9						
N _{Rk,s}	Characteristic tension resistance for stainless steel class A4-80	kN	29	46	67	126	196	282	
γ _{Ms}	Partial safety factor for tension resistance for galvanised steel class A4-80	-	1.6						
N _{Rk,s}	Characteristic tension resistance for stainless steel class 1.4529	kN	26	41	59	110	172	247	
γ _{Ms}	Partial safety factor for tension resistance for galvanised steel class 1.4529	-	1.5						
N _{Rk,s}	Characteristic tension resistance for stainless steel class 1.4565	kN	26	41	59	110	172	247	
γ _{Ms}	Partial safety factor for tension resistance for galvanised steel class 1.4565	-	1.9						

Déclaration UE de conformité CE – DoP

CE 090-046580 / CE 090-046582

Basic requirements on works. Intended use 1: Anchorage of threaded rods in concrete.			Performances						Technical Specification
			M8	M10	M12	M16	M20	M24	
Tension Load: Combined Concrete Cone and Pullout Failure in Non Cracked Concrete C20/25									
τ_{Rk}	Characteristic bond resistance in dry / wet concrete & flooded hole	N/mm ²	6	6	5	5	4	4	EAD 330499-01-0601
γ_{M0}	Partial safety factor ¹	-	1.8						
Ψ_c	C25/30	-	1.04						
	C30/37	-	1.08						
	C35/45	-	1.12						
	C40/50	-	1.15						
	C45/55	-	1.17						
	C50/60	-	1.19						
Tension Load: Splitting Failure									
$s_{cr,sp}$	Critical spacing (splitting)	Mm	4.0 h_{ef}						EAD 330499-01-0601
$c_{cr,sp}$	Critical edge distance (splitting)	Mm	2.0 h_{ef}						
γ_{Msp}	Partial safety factor ¹	-	1.8						
Displacements Under Tension Load									
N	Service tension load	kN	6.3	9.9	15.9	23.8	29.8	37.7	EAD 330499-01-0601
δ_{N0}	Short term displacement	Mm	0.2	0.3	0.4	0.4	0.4	0.6	
$\delta_{N\infty}$	Long term displacement	Mm	0.83	0.83	0.83	0.83	0.83	0.83	

Basic requirements on works. Intended use 1: Anchorage of threaded rods in concrete (continued).			Performances						Technical Specification
			M8	M10	M12	M16	M20	M24	
Shear Load: Steel Failure without lever arm									
$V_{Rk,s}$	Characteristic shear resistance for galvanised steel class 5.8	kN	9	15	21	39	61	88	EAD 330499-01-0601
γ_{Ms}	Partial safety factor for shear resistance for galvanised steel class 5.8	-	1.25						
$V_{Rk,s}$	Characteristic shear resistance for galvanised steel class 8.8	kN	15	23	34	63	98	141	
γ_{Ms}	Partial safety factor for shear resistance for galvanised steel class 8.8	-	1.25						
$V_{Rk,s}$	Characteristic shear resistance for galvanised steel class 10.9	kN	18	29	42	79	123	177	
γ_{Ms}	Partial safety factor for shear resistance for galvanised steel class 10.9	-	1.5						
$V_{Rk,s}$	Characteristic shear resistance for stainless steel class A4-70	kN	13	20	30	55	86	124	
γ_{Ms}	Partial safety factor for shear resistance for galvanised steel class A4-70	-	1.56						
$V_{Rk,s}$	Characteristic shear resistance for stainless steel class A4-80	kN	15	23	34	63	98	141	
γ_{Ms}	Partial safety factor for shear resistance for galvanised steel class A4-80	-	1.33						
$V_{Rk,s}$	Characteristic shear resistance for stainless steel class 1.4529	kN	13	20	30	55	86	124	
γ_{Ms}	Partial safety factor for shear resistance for galvanised steel class 1.4529	-	1.25						
$V_{Rk,s}$	Characteristic shear resistance for stainless steel class 1.4529	kN	13	20	30	55	86	124	
γ_{Ms}	Partial safety factor for shear resistance for galvanised steel class 1.4529	-	1.56						

Déclaration UE de conformité CE – DoP

CE 090-046580 / CE 090-046582

Shear Load: Steel Failure with lever arm										
$M_{Rk,s}^0$	Characteristic bending moment for galvanised steel class 5.8	Nm	19	37	66	166	325	561	EAD 330499-01-0601	
γ_{Ms}	Partial safety factor for galvanised steel class 5.8	-	1.25							
$M_{Rk,s}^0$	Characteristic bending moment for galvanised steel class 8.8	Nm	30	60	105	266	519	898		
γ_{Ms}	Partial safety factor for galvanised steel class 8.8	-	1.25							
$M_{Rk,s}^0$	Characteristic bending moment for galvanised steel class 10.9	Nm	37	75	131	333	649	1123		
γ_{Ms}	Partial safety factor for galvanised steel class 10.9	-	1.5							
$M_{Rk,s}^0$	Characteristic bending moment for stainless steel class A4-70	Nm	26	52	92	233	454	786		
γ_{Ms}	Partial safety factor for stainless steel class A4-70	-	1.56							
$M_{Rk,s}^0$	Characteristic bending moment for stainless steel class A4-80	Nm	30	60	105	266	519	898		
γ_{Ms}	Partial safety factor for stainless steel class A4-80	-	1.33							
$M_{Rk,s}^0$	Characteristic bending moment for stainless steel class 1.4529	Nm	26	52	92	233	454	786		
γ_{Ms}	Partial safety factor for stainless steel class 1.4529	-	1.25							
$M_{Rk,s}^0$	Characteristic bending moment for stainless steel class 1.4529	Nm	26	52	92	233	454	786		
γ_{Ms}	Partial safety factor for stainless steel class 1.4529	-	1.56							

Basic requirements on works. Intended use 1: Anchorage of threaded rods in concrete (continued).			Performances						Technical Specification
			M8	M10	M12	M16	M20	M24	
Shear Load: Concrete Pryout Failure									
K	K factor	-	2						EAD 330499-01-0601
γ_{Mp}	Partial safety factor	-	1.5						
Shear Load: Concrete Edge Failure									
<input type="checkbox"/>			See section 5.2.3.4 of Technical Report TR029						EAD 330499-01-0601
γ_{Mc}	Partial safety factor	-	1.5						
Displacements Under Shear Load									
V	Service shear load	kN	3.5	5.5	8.0	15.0	23.3	33.6	EAD 330499-01-0601
δ_{V0}	Short term displacement	Mm	2.5	2.5	2.5	2.5	2.5	2.5	
$\delta_{V\infty}$	Long term displacement	Mm	3.7	3.7	3.7	3.7	3.7	3.7	
1In the absence of other national regulations									

Déclaration UE de conformité CE – DoP

CE 090-046580 / CE 090-046582

Basic requirements on works. Intended use 2: Anchorage of threaded rods in hollow or perforated masonry.		Performances						Technical Specification	
		M8		M10		M12			
Installation Parameters									
Anchor rod with sieve sleeve									
l _s	Sieve Sleeve	Mm	85		85		85		EAD 330076-00-0604
d _s		Mm	15	16	15	16	20		
d _o	Nominal drill hole diameter	Mm	15	16	15	16	20		
d _b	Diameter of cleaning brush	Mm	20 ^{±1}		20 ^{±1}		22 ^{±1}		
h _o	Depth of the drill hole	Mm	90						
h _{ef}	Effective anchorage depth	Mm	85						
d _r ≤	Diameter of clearance hole in the fixture	Mm	9		12		14		
T _{inst}	Torque moment	Nm	2						

Edge Distances and Spacings						
Base material	Anchor rods					
	M8, M10			M12		
	C _{cr} = C _{min}	S _{cr II} = S _{min II}	S _{cr L} = S _{min L}	C _{cr} = C _{min}	S _{cr II} = S _{min II}	S _{cr L} = S _{min L}
	mm	mm	mm	mm	mm	mm
Brick number 1	100	235	115	100	235	115
Brick number 2	128	255	255	128	255	255
Brick number 3	128	255	255	128	255	255
Brick number 4	100	250	240	100	250	240
Brick number 5	100	370	238	100	370	238
Brick number 6	100	245	110	100	245	110
Brick number 7	100	373	238	100	373	238

Déclaration UE de conformité CE – DoP

CE 090-046580 / CE 090-046582

Characteristic Bending Moment						
Size			M8	M10	M12	
Steel grade 5.8:	Nm	$M^0_{Rk,s}$	19	37	66	
Steel grade 8.8:	Nm	$M^0_{Rk,s}$	30	60	105	
Steel grade 10.9:	Nm	$M^0_{Rk,s}$	37	75	131	
Stainless steel grade A2-70, A4-70:	Nm	$M^0_{Rk,s}$	26	52	92	
Stainless steel grade A4-80:	Nm	$M^0_{Rk,s}$	30	60	105	
Stainless steel grade 1.4529 strength class 70:	Nm	$M^0_{Rk,s}$	26	52	92	
Stainless steel grade 1.4565 strength class 70:	Nm	$M^0_{Rk,s}$	26	52	92	
Characteristic resistance under tension and shear loading						
Base material			Anchor Rods $= V_{Rk} (kN)^2$			β - Factors for job site tests according to ETAG 029, Annex B
			M8	M10	M12	
Brick number 1			2.0	2.0	2.0	
Brick number 2			1.2	1.5	2.5	
Brick number 3			0.5	0.75	1.2	
Brick number 4			0.6	0.75	0.75	
Brick number 5			1.2	1.2	2.0	
Brick number 6			0.5	0.5	0.5	
Brick number 7			1.2	1.2	1.5	

Displacements					
Base material	F (kN)	δ_{N0}	$\delta_{N\infty}$ (mm)	δ_{V0} (mm)	$\delta_{V\infty}$ (mm)
Solid bricks	$N_{Rk} / (1.4 \gamma_M)$	0.6	1.2	1.0 ³⁾	1.5 ³⁾
Perforated and hollow bricks	$N_{Rk} / (1.4 \gamma_M)$	0.14	0.28	1.0 ³⁾	1.5 ³⁾

²⁾ In absence of other national regulations ³⁾ the hole gap between bolt and fixture shall be considered additionally

Déclaration UE de conformité CE – DoP

CE 090-046580 / CE 090-046582

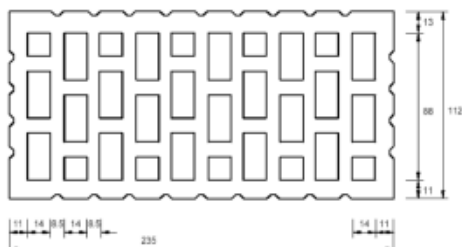
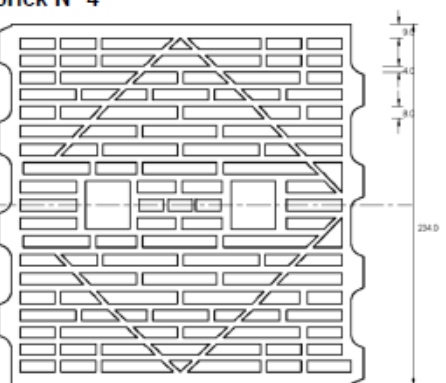
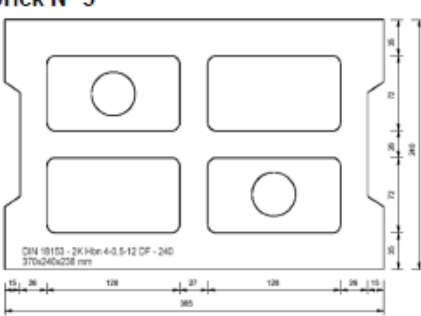
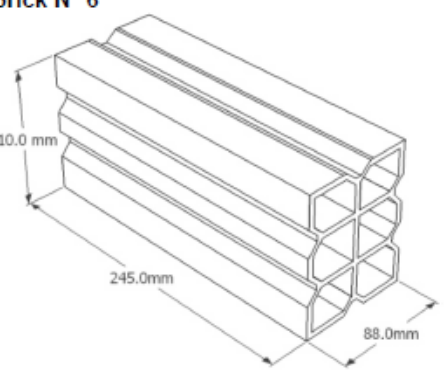
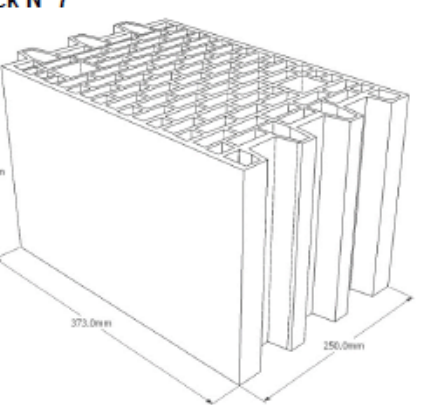
<p>Brick N° 1</p>  <p>Hollow clay brick HLz 12-1,0-2DF according to EN 771-1 length/width/height = 235 mm/112 mm/115 mm $f_b \geq 12 \text{ N/mm}^2 / \rho \geq 1,0 \text{ kg/dm}^3$</p>	<p>Brick N° 2</p> <p>Solid clay brick Mz 12-2,0-NF according to EN 771-1 length/width/height = 240 mm/116 mm/71 mm $f_b \geq 12 \text{ N/mm}^2 / \rho \geq 2,0 \text{ kg/dm}^3$</p>
<p>Brick N° 4</p>  <p>Hollow clay brick HLzW 6-0,7-8DF according to EN 771-1 length/width/height = 250 mm/240 mm/240 mm $f_b \geq 6 \text{ N/mm}^2 / \rho \geq 0,8 \text{ kg/dm}^3$</p>	<p>Brick N° 5</p>  <p>Concrete masonry unit Hbn 4-12DF according to EN 771-3 length/width/height = 370 mm/240 mm/238 mm $f_b \geq 4 \text{ N/mm}^2 / \rho \geq 1,2 \text{ kg/dm}^3$</p>
<p>Brick N° 6</p>  <p>Hollow clay brick Hueco Doble according to EN 771-1 length/width/height = 245 mm/110 mm/88 mm $f_b \geq 2,5 \text{ N/mm}^2 / \rho \geq 0,74 \text{ kg/dm}^3$</p>	<p>Brick N° 7</p>  <p>Hollow clay brick Porotherm 25 P+W KL15 according to EN 771-1 length/width/height = 373 mm/250 mm/238 mm $f_b \geq 12 \text{ N/mm}^2 / \rho \geq 0,9 \text{ kg/dm}^3$</p>

Déclaration UE de conformité CE – DoP

CE 090-046580 / CE 090-046582

7. Les performances du produit identifié ci-dessus sont conformes aux performances déclarées. Conformément au règlement (UE) no 305/2011, la présente déclaration des performances est établie sous la seule responsabilité du fabricant mentionné ci-dessus.

Signé par et au nom de:

POIZAT.B



Le 30/01/2020